

LM1085

3A Low Dropout Positive Regulators

General Description

The LM1085 is a series of low dropout positive voltage regulators with a maximum dropout of 1.5V at 3A of load current. It has the same pin-out as National Semiconductor's industry standard LM317.

The LM1085 is available in an adjustable version, which can set the output voltage with only two external resistors. It is also available in three fixed voltages: 3.3V, 5.0V and 12.0V. The fixed versions integrate the adjust resistors.

The LM1085 circuit includes a zener trimmed bandgap reference, current limiting and thermal shutdown.

The LM1085 series is available in TO-220 and TO-263 packages. Refer to the LM1084 for the 5A version, and the LM1086 for the 1.5A version.

Features

- Available in 3.3V, 5.0V, 12V and Adjustable Versions
- Current Limiting and Thermal Protection
- Output Current 3A
- Line Regulation 0.015% (typical)
- Load Regulation 0.1% (typical)

Applications

- High Efficiency Linear Regulators
- Battery Charger
- Post Regulation for Switching Supplies
- Constant Current Regulator
- Microprocessor Supply

Connection Diagrams

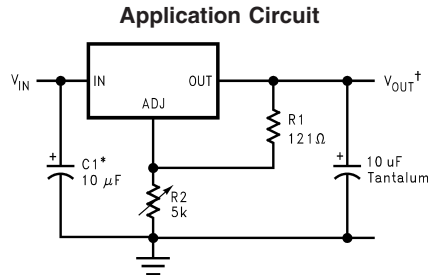
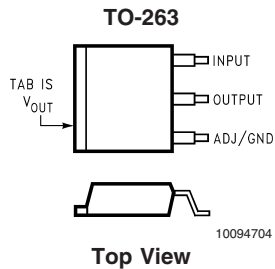
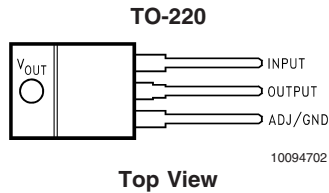

*NEEDED IF DEVICE IS FAR FROM FILTER CAPACITORS

$$V_{OUT}^{\dagger} = 1.25V \left(1 + \frac{R2}{R1}\right)$$

10094752

1.2V to 15V Adjustable Regulator

Basic Functional Diagram, Adjustable Version

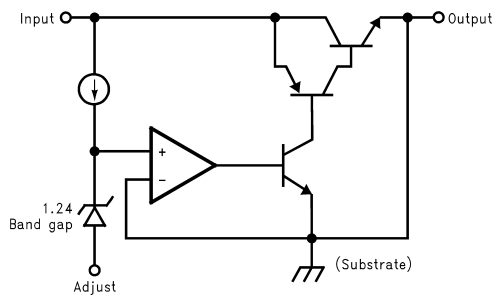

10094765

Ordering Information

Package	Temperature Range	Part Number	Transport Media	NSC Drawing
3-lead TO-263	-40°C to +125°C	LM1085IS-ADJ	Rails	TS3B
		LM1085ISX-ADJ	Tape and Reel	
		LM1085IS-12	Rails	
		LM1085ISX-12	Tape and Reel	
		LM1085IS-3.3	Rails	
		LM1085ISX-3.3	Tape and Reel	
		LM1085IS-5.0	Rails	
		LM1085ISX-5.0	Tape and Reel	
3-lead TO-220	-40°C to + 125°C	LM1085IT-ADJ	Rails	T03B
		LM1085IT-12	Rails	
		LM1085IT-3.3	Rails	
		LM1085IT-5.0	Rails	

Simplified Schematic

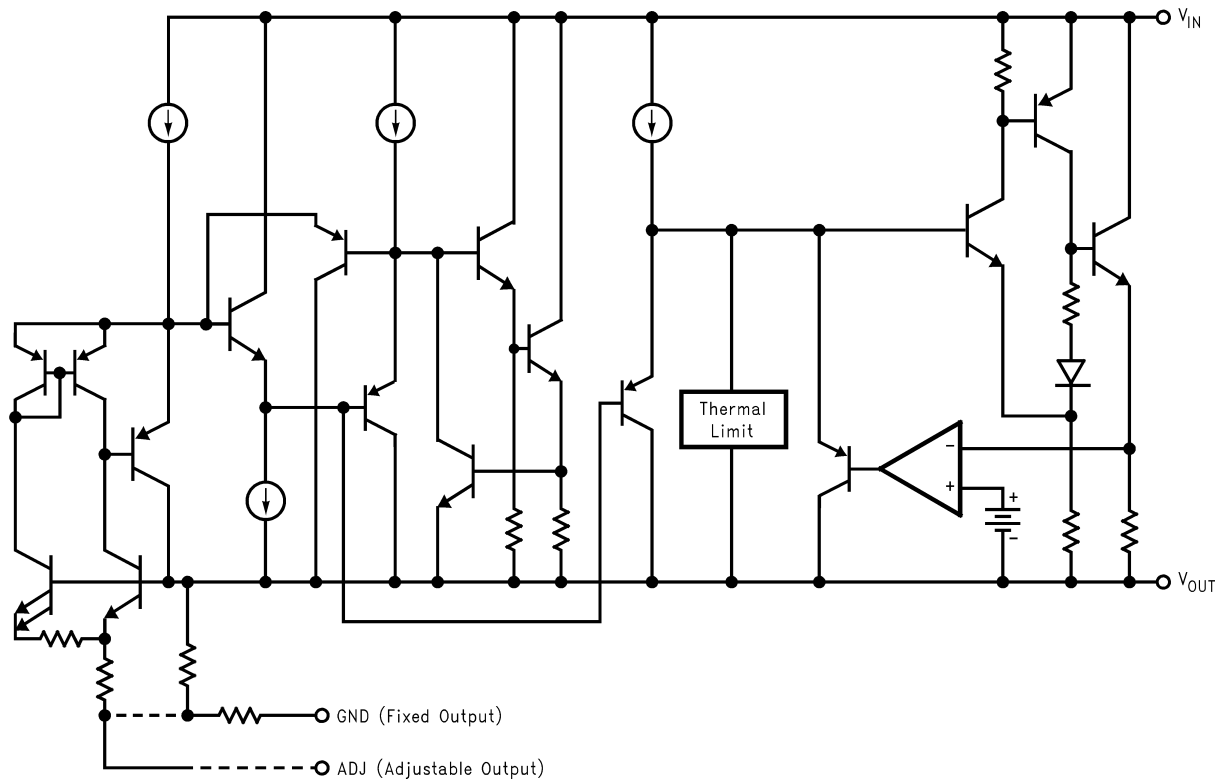

10094734

Absolute Maximum Ratings (Note 1)

If Military/Aerospace specified devices are required, please contact the National Semiconductor Sales Office/Distributors for availability and specifications.

Maximum Input to Output Voltage Differential

LM1085-ADJ	29V
LM1085-12	18V
LM1085-3.3	27V
LM1085-5.0	25V
Power Dissipation (Note 2)	Internally Limited

Junction Temperature (T_J) (Note 3)	150°C
Storage Temperature Range	-65°C to 150°C
Lead Temperature	260°C, to 10 sec
ESD Tolerance (Note 4)	2000V

Operating Ratings (Note 1)

Junction Temperature Range (T_J) (Note 3)	
Control Section	-40°C to 125°C
Output Section	-40°C to 150°C

Electrical Characteristics

Typicals and limits appearing in normal type apply for $T_J = 25^\circ\text{C}$. Limits appearing in **Boldface** type apply over the entire junction temperature range for operation.

Symbol	Parameter	Conditions	Min (Note 6)	Typ (Note 5)	Max (Note 6)	Units
V_{REF}	Reference Voltage	LM1085-ADJ $I_{OUT} = 10\text{mA}$, $V_{IN} - V_{OUT} = 3\text{V}$	1.238	1.250	1.262	V
		$10\text{mA} \leq I_{OUT} \leq I_{FULL\ LOAD}$, $1.5\text{V} \leq (V_{IN} - V_{OUT}) \leq 15\text{V}$ (Note 7)	1.225	1.250	1.270	V
V_{OUT}	Output Voltage (Note 7)	LM1085-3.3 $I_{OUT} = 0\text{mA}$, $V_{IN} = 5\text{V}$ $0 \leq I_{OUT} \leq I_{FULL\ LOAD}$, $4.8\text{V} \leq V_{IN} \leq 15\text{V}$	3.270 3.235	3.300 3.300	3.330 3.365	V V
		LM1085-5.0 $I_{OUT} = 0\text{mA}$, $V_{IN} = 8\text{V}$ $0 \leq I_{OUT} \leq I_{FULL\ LOAD}$, $6.5\text{V} \leq V_{IN} \leq 20\text{V}$	4.950 4.900	5.000 5.000	5.050 5.100	V V
		LM1085-12 $I_{OUT} = 0\text{mA}$, $V_{IN} = 15\text{V}$ $0 \leq I_{OUT} \leq I_{FULL\ LOAD}$, $13.5\text{V} \leq V_{IN} \leq 25\text{V}$	11.880 11.760	12.000 12.000	12.120 12.240	V V
ΔV_{OUT}	Line Regulation (Note 8)	LM1085-ADJ $I_{OUT} = 10\text{mA}$, $1.5\text{V} \leq (V_{IN} - V_{OUT}) \leq 15\text{V}$		0.015 0.035	0.2 0.2	% %
		LM1085-3.3 $I_{OUT} = 0\text{mA}$, $4.8\text{V} \leq V_{IN} \leq 15\text{V}$		0.5 1.0	6 6	mV mV
		LM1085-5.0 $I_{OUT} = 0\text{mA}$, $6.5\text{V} \leq V_{IN} \leq 20\text{V}$		0.5 1.0	10 10	mV mV
		LM1085-12 $I_{OUT} = 0\text{mA}$, $13.5\text{V} \leq V_{IN} \leq 25\text{V}$		1.0 2.0	25 25	mV mV
ΔV_{OUT}	Load Regulation (Note 8)	LM1085-ADJ $(V_{IN} - V_{OUT}) = 3\text{V}$, $10\text{mA} \leq I_{OUT} \leq I_{FULL\ LOAD}$		0.1 0.2	0.3 0.4	% %
		LM1085-3.3 $V_{IN} = 5\text{V}$, $0 \leq I_{OUT} \leq I_{FULL\ LOAD}$		3 7	15 20	mV mV
		LM1085-5.0 $V_{IN} = 8\text{V}$, $0 \leq I_{OUT} \leq I_{FULL\ LOAD}$		5 10	20 35	mV mV
		LM1085-12 $V_{IN} = 15\text{V}$, $0 \leq I_{OUT} \leq I_{FULL\ LOAD}$		12 24	36 72	mV mV
	Dropout Voltage (Note 9)	LM1085-ADJ, 3.3, 5, 12 ΔV_{REF} , $\Delta V_{OUT} = 1\%$, $I_{OUT} = 3\text{A}$		1.3	1.5	V

Electrical Characteristics (Continued)

Typicals and limits appearing in normal type apply for $T_J = 25^\circ\text{C}$. Limits appearing in **Boldface** type apply over the entire junction temperature range for operation.

Symbol	Parameter	Conditions	Min (Note 6)	Typ (Note 5)	Max (Note 6)	Units
I_{LIMIT}	Current Limit	LM1085-ADJ $V_{IN}-V_{OUT} = 5V$	3.2	5.5		A
		$V_{IN}-V_{OUT} = 25V$	0.2	0.5		A
		LM1085-3.3 $V_{IN} = 8V$	3.2	5.5		A
		LM1085-5.0 $V_{IN} = 10V$	3.2	5.5		A
		LM1085-12 $V_{IN} = 17V$	3.2	5.5		A
	Minimum Load Current (Note 10)	LM1085-ADJ $V_{IN} - V_{OUT} = 25V$		5.0	10.0	mA
	Quiescent Current	LM1085-3.3 $V_{IN} \leq 18V$		5.0	10.0	mA
		LM1085-5.0 $V_{IN} \leq 20V$		5.0	10.0	mA
		LM1085-12 $V_{IN} \leq 25V$		5.0	10.0	mA
	Thermal Regulation	$T_A = 25^\circ\text{C}$, 30ms Pulse		.004	0.02	%/W
	Ripple Rejection	$f_{RIPPLE} = 120\text{Hz}$, $C_{OUT} = 25\mu\text{F}$ Tantalum, $I_{OUT} = 3A$				
		LM1085-ADJ, $C_{ADJ} = 25\mu\text{F}$, $(V_{IN}-V_O) = 3V$	60	75		dB
		LM1085-3.3, $V_{IN} = 6.3V$	60	72		dB
		LM1085-5.0, $V_{IN} = 8V$	60	68		dB
		LM1085-12 $V_{IN} = 15V$	54	60		dB
	Adjust Pin Current	LM1085		55	120	μA
	Adjust Pin Current Change	$10\text{mA} \leq I_{OUT} \leq I_{FULL\ LOAD}$, $1.5V \leq V_{IN}-V_{OUT} \leq 25V$		0.2	5	μA
	Temperature Stability			0.5		%
	Long Term Stability	$T_A=125^\circ\text{C}$, 1000Hrs		0.3	1.0	%
	RMS Output Noise (% of V_{OUT})	$10\text{Hz} \leq f \leq 10\text{kHz}$		0.003		%
	Thermal Resistance Junction-to-Case	3-Lead TO-263: Control Section/Output Section			0.7/3.0	$^\circ\text{C/W}$
		3-Lead TO-220: Control Section/Output Section			0.7/3.0	$^\circ\text{C/W}$

Note 1: Absolute Maximum Ratings indicate limits beyond which damage to the device may occur. Operating Ratings indicate conditions for which the device is intended to be functional, but specific performance is not guaranteed. For guaranteed specifications and the test conditions, see the Electrical Characteristics.

Note 2: Power dissipation is kept in a safe range by current limiting circuitry. Refer to Overload Recovery in Application Notes.

Note 3: The maximum power dissipation is a function of $T_{J(max)}$, θ_{JA} , and T_A . The maximum allowable power dissipation at any ambient temperature is $P_D = (T_{J(max)} - T_A) / \theta_{JA}$. All numbers apply for packages soldered directly into a PC board. Refer to Thermal Considerations in the Application Notes.

Note 4: For testing purposes, ESD was applied using human body model, 1.5k Ω in series with 100pF.

Note 5: Typical Values represent the most likely parametric norm.

Note 6: All limits are guaranteed by testing or statistical analysis.

Note 7: $I_{FULL\ LOAD}$ is defined in the current limit curves. The $I_{FULL\ LOAD}$ Curve defines the current limit as a function of input-to-output voltage. Note that 30W power dissipation for the LM1085 is only achievable over a limited range of input-to-output voltage.

Note 8: Load and line regulation are measured at constant junction temperature, and are guaranteed up to the maximum power dissipation of 30W. Power dissipation is determined by the input/output differential and the output current. Guaranteed maximum power dissipation will not be available over the full input/output range.

Note 9: Dropout voltage is specified over the full output current range of the device.

Note 10: The minimum output current required to maintain regulation.

Physical Dimensions inches (millimeters) unless otherwise noted

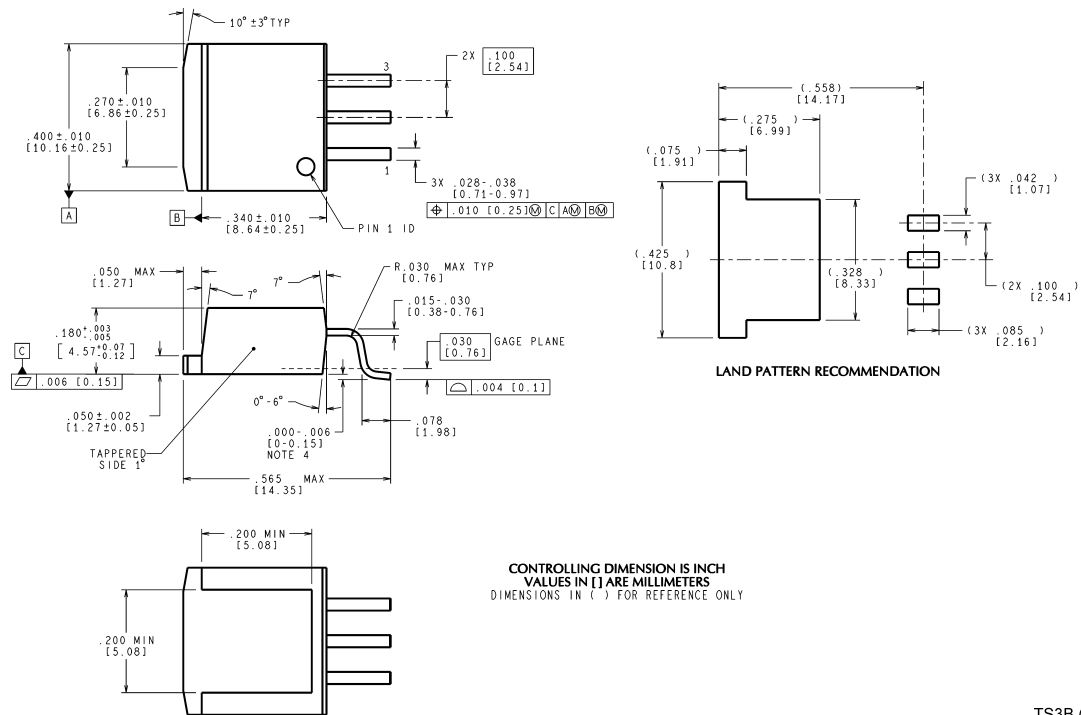

TS3B (Rev F)

**3-Lead TO-263
NS Package Number TS3B**

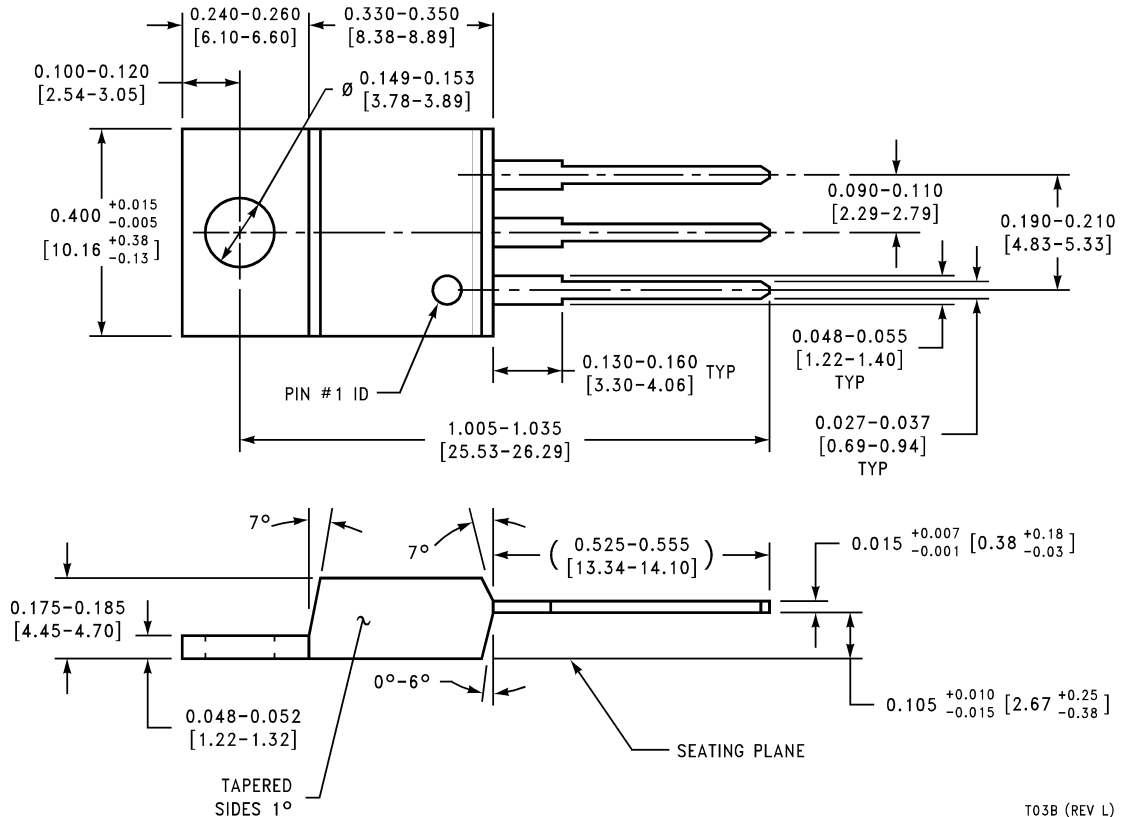

T03B (REV L)

**3-Lead TO-220
NS Package Number T03B**